

Surface Mount Schottky Barrier Rectifier

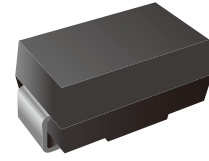

Features

- The plastic package carries Underwriters Laboratory Flammability Classification 94V-0
- For surface mounted applications
- Metal silicon junction, majority carrier conduction
- Low power loss, high efficiency
- Built-in strain relief, ideal for automated placement
- High forward surge current capability
- High temperature soldering guaranteed: 260°C/10 seconds at terminals

Functional Diagram



Mechanical Data

- **Case:** JEDEC DO-214AC molded plastic body
- **Terminals:** leads solderable per MIL-STD-750, Method 2026
- **Polarity:** Color band denotes cathode end
- **Mounting Position:** Any
- **Weight:** 0.002 ounce, 0.07 grams
- **Marking:** SS14

Maximum Ratings and Electrical Characteristics

Ratings at 25°C ambient temperature unless otherwise specified.
 Single phase half-wave 60Hz, resistive or inductive load, for capacitive load current derate by 20%.

	SYMBOLS	LT14AL	UNITS
Maximum repetitive peak reverse voltage	V_{RRM}	40	VOLTS
Maximum RMS voltage	V_{RMS}	28	VOLTS
Maximum DC blocking voltage	V_{DC}	40	VOLTS
Maximum average forward rectified current at TL(see fig.1)	$I_{(AV)}$	1.0	Amp
Peak forward surge current 8.3ms single half sine-wave superimposed on rated load (JEDEC Method)	I_{FSM}	30.0	Amps
Maximum instantaneous forward voltage at 1.0A	V_F	0.55	Volts
Maximum DC reverse current $T_A=25^{\circ}C$ at rated DC blocking voltage $T_A=100^{\circ}C$	I_R	0.1 10	mA
Typical junction capacitance (NOTE 1)	C_J	110	pF
Typical thermal resistance (NOTE 2)	$R_{\theta JA}$	90	$^{\circ}C/W$
Operating junction temperature range	T_J	-55 to +125	$^{\circ}C$
Storage temperature range	T_{STG}	-55 to +150	$^{\circ}C$

Note: 1. Measured at 1MHz and applied reverse voltage of 4.0V D.C.
 2. P.C.B. mounted with 2.0" x 2.0" (5.0x5.0cm) copper pad areas

Ratings and Characteristics Curves

Fig.1 Forward Current Derating Curve

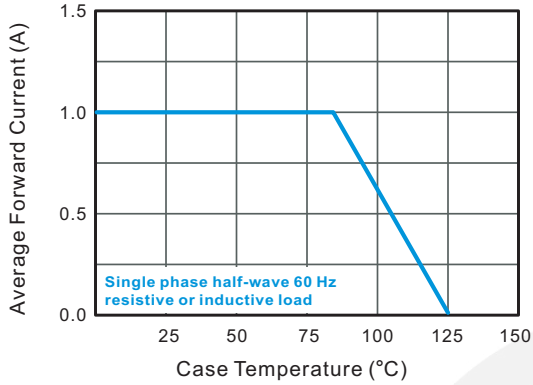

Fig.2 Typical Reverse Characteristics

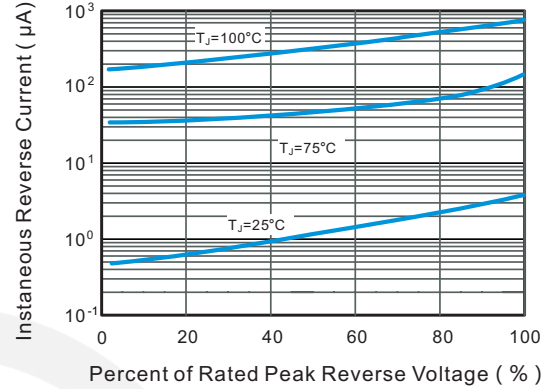

Fig.3 Typical Forward Characteristic

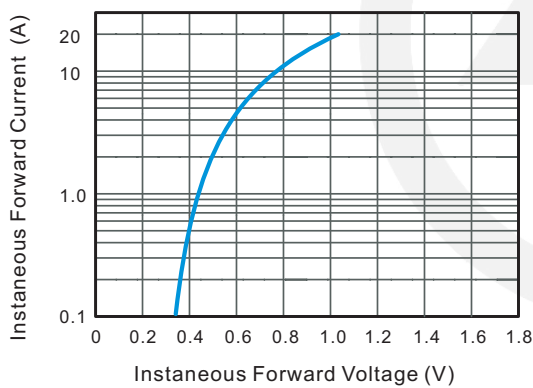

Fig.4 Typical Junction Capacitance

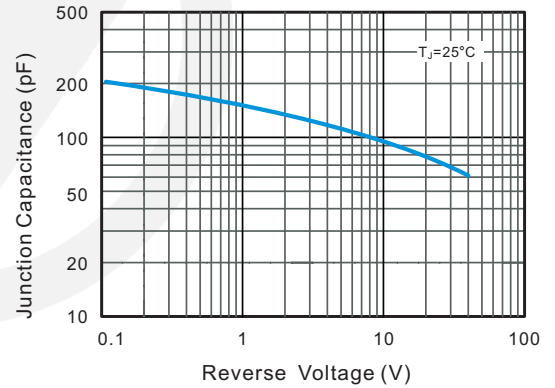

Fig.5 Maximum Non-Repetitive Peak Forward Surge Current

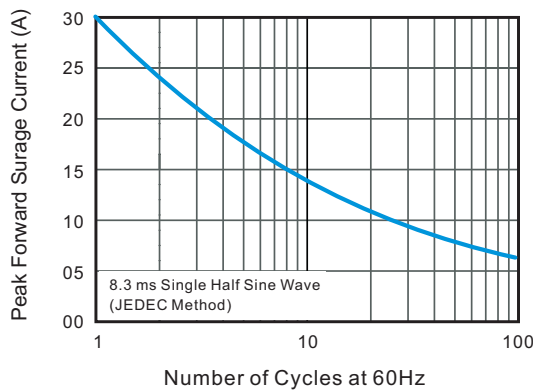
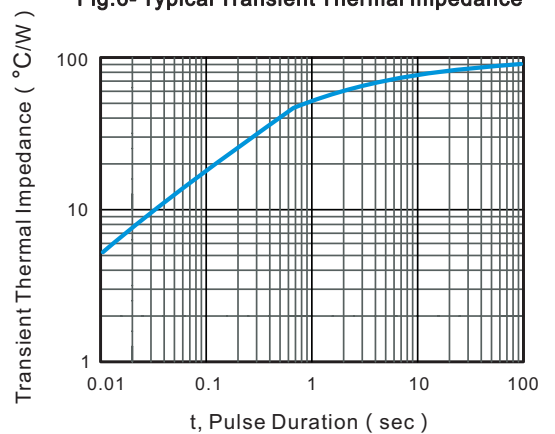
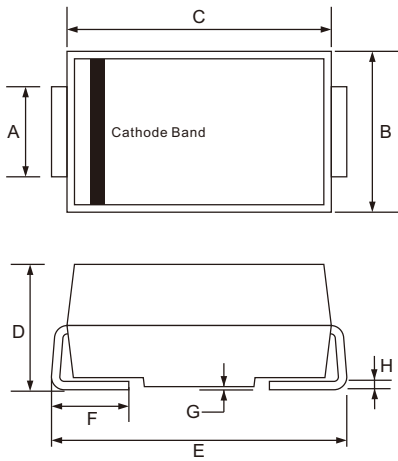

Fig.6- Typical Transient Thermal Impedance



SMA Package Outline Plastic surface mounted package



Unit : mm

SYMBOL	DIMENSIONS	
	MIN.	MAX.
A	1.25	1.65
B	2.30	2.79
C	4.00	4.75
D	1.90	2.50
E	4.70	5.28
F	0.76	1.52
G	0.203 TYP.	
H	0.15	0.31

SMA Suggested Pad Layout

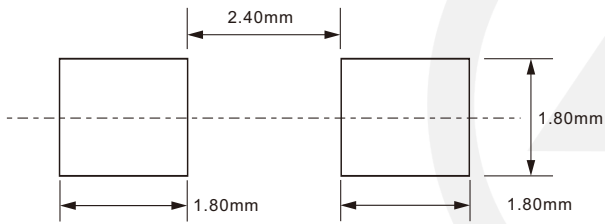

Note:

1. Controlling dimension: in millimeters.
2. General tolerance: $\pm 0.05\text{mm}$
3. The pad layout is for reference purpose only.

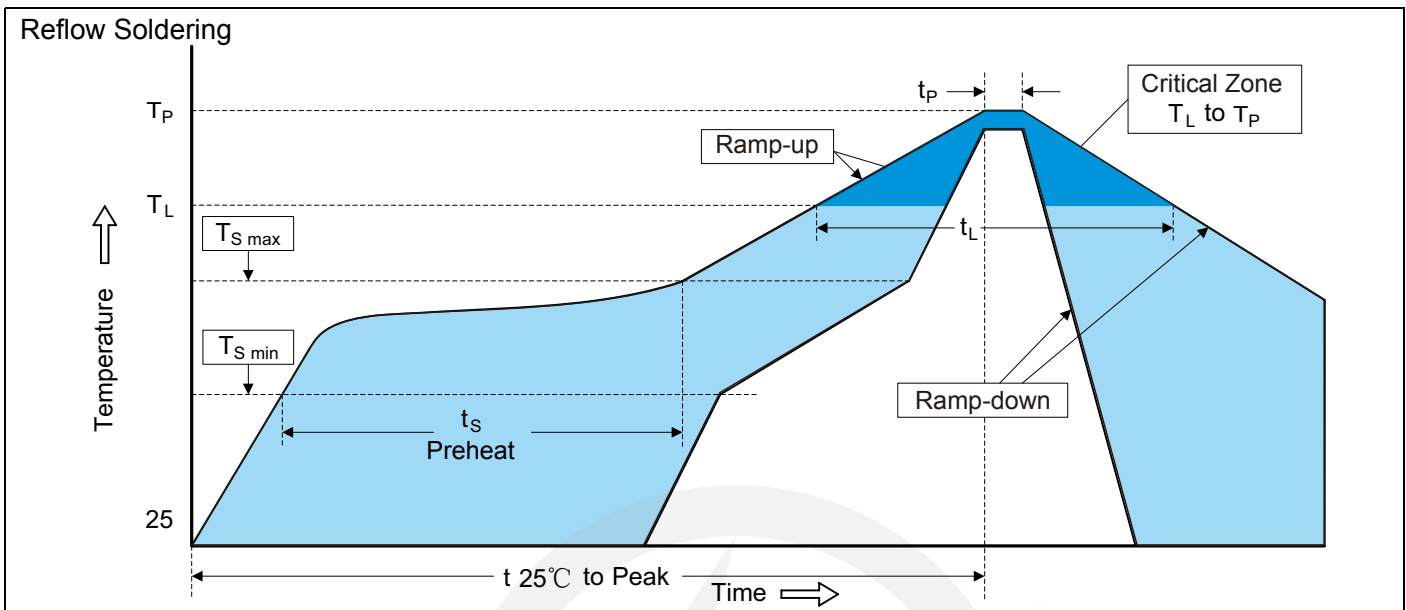
Recommended Soldering Conditions

Recommended Conditions

Profile Feature	Pb-Free Assembly
Average ramp-up rate (T _L to T _P)	3°C/second max.
Preheat -Temperature Min (T _{S min}) -Temperature Max (T _{S max}) -Time (min to max) (t _s)	150°C 200°C 60-180 seconds
T _{S max} to T _L -Ramp-up Rate	3°C/second max.
Time maintained above: -Temperature (T _L) -Time (t _L)	217°C 60-150 seconds
Peak Temperature (T _P)	260°C
Time within 5°C of actual Peak Temperature (t _P)	20-40 seconds
Ramp-down Rate	6°C/second max.
Time 25°C to Peak Temperature	8 minutes max.

Packaging

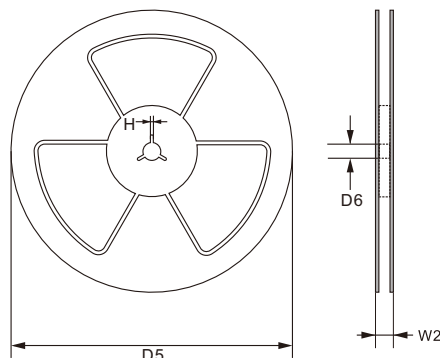
13" Reel



D5 Φ330.0±2.0

D6 Φ13.5±0.5

H 2.5±1.0

W2 16.0±2.0

Quantity: 5000PCS